

FLUID COOLERS DRY COOLERS

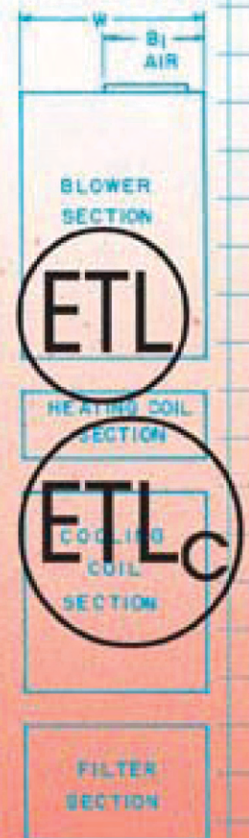

COIL COMPANY
HEAT EXCHANGE • AIR HANDLING



3223 Phoenixville Pike, Malvern, PA 19355

800-523-7590

Phone 610-251-0257 • Fax 610-251-0805

www.CoilCompany.com

TABLE OF CONTENTS

Fluid Coolers	Page
FCV Nomenclature	3
FCV Features & Construction	4
FCV Engineering Specifications	5
FCV Fan/Coil Data	6
FCV Unit Weights and Volumes	7
FCV Fan and Motor Data	8-9
Dimensions	10-14
Standard and Optional Leg Dimensions and Connection Sizes	15

Replacement Engineering Made Easy



COIL COMPANY
HEAT EXCHANGE · AIR HANDLING

1-800-523-7590

FAX: (610) 251-0805

MODEL NUMBER IDENTIFICATION

FCV-03-S-30-4-214-017-C-2

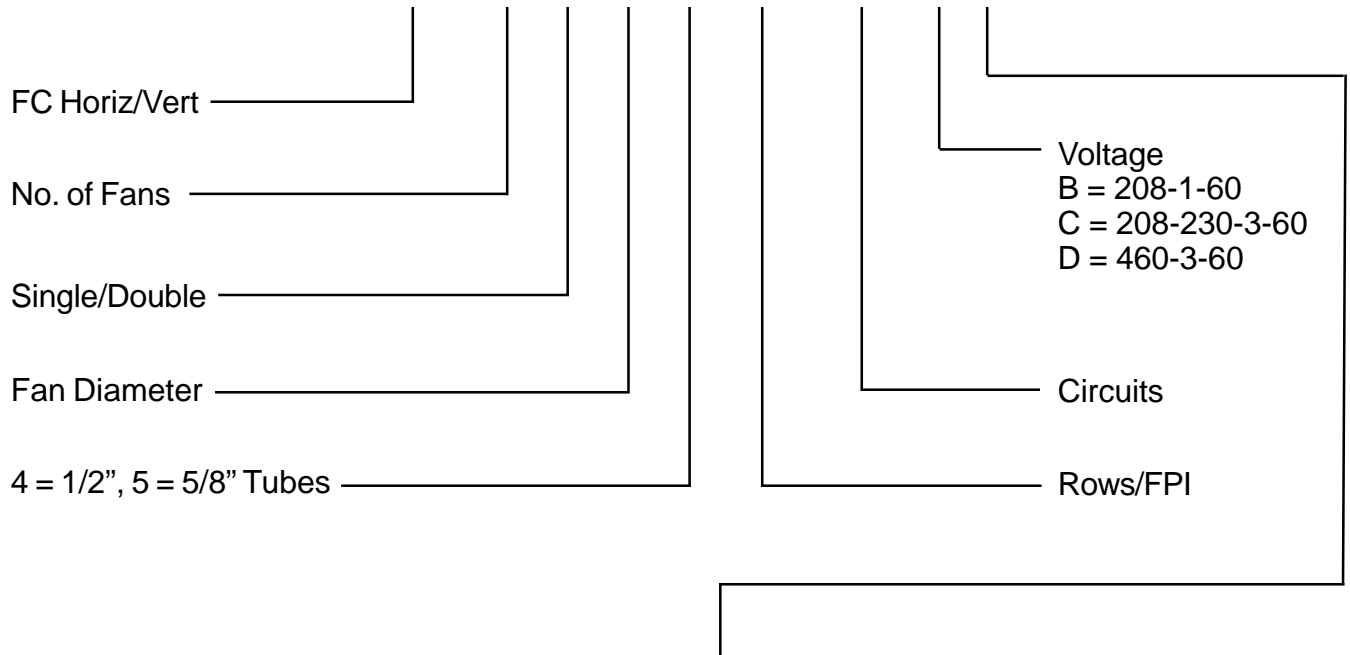

CONNECTION SIZES *

NO.	GPM RANGE	INLET & OUTLET	
		QTY.	SIZE
1	10-20	1	1 1/4
2	20-40	1	1 1/2
3	40-70	1	2
4	70-100	1	2 1/2
5	100-150	1	3
6	150-200	2	2 1/2
7	200-300	2	3
8	300-450	3	3
9	450-550	4	3

* All connections are MPT unless specified otherwise.

STANDARD FEATURES

COILS

- 1/2"OD copper tubes, .017" wall thickness or 5/8" O.D. copper tubes, .020 wall thickness.
- Aluminum fins - .006" thick - 6 fins/inch to 14 fins/inch.
- Galvanized steel casing with aluminum tube sheets.

FAN SECTION

- Aluminum fan blades with painted steel hubs.
- Motors - open type 6 pole energy efficient - 1140 RPM.
- Each module fully baffled.
- Motors mounted on 12 ga. motor rails.

CONTROL PANEL

- Weatherproof enclosure with all motor leads terminated at panel.

GENERAL CONSTRUCTION

- Galvanized steel frame and cabinet - 16 ga. cabinet, 12 ga. rails and legs, 12 ga. motor rails.
- Telescoping legs mounted on FCV-02S-26 and larger units.

OPTIONAL FEATURES

COILS

- Upgrade fin thickness to .010" thick aluminum
- Substitute .006" thick copper fins in lieu of aluminum
- Epoxy coat or phenolic coat coils

CONTROL PANEL

- Supply fan cycling controls to include aquastat & control transformer.
- Control circuit toggle switches or terminal blocks.
- Mounted disconnect switch
- Motor fusing

UNIT CONFIGURATION

- Single fan-width units: up to three fans can be constructed for horizontal air flow.

TYPICAL ENGINEERING SPECIFICATIONS

GENERAL

USA Coil & Air model FCV units shall be furnished as per the following specifications in vertical airflow (FCV). Units shall be ETL and ETLc listed.

UNIT CABINETS

- Housing shall be constructed of heavy-gauge galvanized steel for maximum rigidity and corrosion protection.
- All multiple fan units shall have individual fan sections, separated by full width baffles to prevent air bypass and provide additional casing rigidity.
- Unit sizes FCV-02S-26 and larger shall be provided with lifting eyes for rigging.
- Unit sizes FCV-02S-26 through FCV12D-30 shall be provided with 12 gauge galvanized steel telescoping legs factory-mounted for convenient unit installation.

FLUID COIL

- Coils shall be constructed of seamless 1/2-inch or 5/8-inch O.D. copper tubing on a staggered pattern.
- All tubes shall be mechanically expanded into full-collared plate-type aluminum (or optional copper) fins for permanent contact and maximum heat transfer efficiency.
- All coils shall be leak tested at 550 psig with dry nitrogen.

FANS

- Fans shall be propeller type with aluminum blades and painted steel hubs. Fans shall be dynamically balanced and factory run tested before shipping.
- Fans shall have dual set screws spaced 90 degrees apart which seat onto one flat and one keyway on the shafts.

FAN GUARDS

- Fan guards shall be heavy gauge steel wire with vinyl coating for maximum protection and attractive appearance.

FAN MOTORS

- Fan motors shall be heavy duty PSC or three phase open drip-proof with built-in overload protection and permanently lubricated ball bearings.
- All motors shall have a rigid base mounted to 12 gauge galvanized steel rails. Motors shall be factory wired with leads terminating in a weather-tight enclosure.

FCV SINGLE AND DOUBLE FAN-WIDTH UNITS

FLUID COOLER SINGLE WIDTH				
Model #	# Fans	Face Area (sq. ft.)	Rows Deep	Fins
FCV-01S-18-4-108	1	4.3	1	8
FCV-01S-18-4-208	1	4.3	2	8
FCV-01S-22-4-210	1	6.3	2	10
FCV-01S-22-4-310	1	6.3	3	10
FCV-02S-22-4-208	2	12.5	2	8
FCV-02S-22-4-310	2	12.5	3	10
FCV-02S-22-4-410	2	12.5	4	10
FCV-02S-26-4-208	2	31.3	2	8
FCV-02S-26-4-210	2	31.3	2	10
FCV-02S-26-4-308	2	31.3	3	8
FCV-02S-26-4-310	2	31.3	3	10
FCV-02S-30-4-214	2	31.3	2	14
FCV-02S-30-4-310	2	31.3	3	10
FCV-02S-30-4-314	2	31.3	3	14
FCV-02S-30-4-414	2	31.3	4	14
FCV-03S-30-4-210	3	46.9	3	10
FCV-03S-30-4-314	3	46.9	3	14
FCV-03S-30-4-412	3	46.9	4	12
FCV-04S-30-4-310	4	62.6	3	10
FCV-04S-30-4-314	4	62.6	3	14
FCV-04S-30-4-412	4	62.6	4	12
FCV-04S-30-4-414	4	62.6	4	14
FCV-05S-30-4-314	5	78.2	3	14
FCV-05S-30-4-410	5	78.2	4	10
FCV-05S-30-4-412	5	78.2	4	12
FCV-05S-30-4-414	5	78.2	4	14
FCV-06S-30-4-410	6	93.9	4	10
FCV-05S-30-4-412	6	93.9	4	12
FCV-05S-30-4-414	6	93.9	4	14

FLUID COOLER DOUBLE WIDTH				
Model #	# Fans	Face Area (sq. ft.)	Rows Deep	Fins
FCV-04D-30-4-214	4	62.6	2	14
FCV-04D-30-4-310	4	62.6	3	10
FCV-04D-30-4-314	4	62.6	3	14
FCV-04D-30-4-412	4	62.6	4	12
FCV-04D-30-4-414	4	62.6	4	14
FCV-06D-30-4-214	6	93.9	2	14
FCV-06D-30-4-310	6	93.9	3	10
FCV-06D-30-4-312	6	93.9	3	12
FCV-06D-30-4-314	6	93.9	3	14
FCV-06D-30-4-412	6	93.9	4	12
FCV-06D-30-4-414	6	93.9	4	14
FCV-08D-30-4-310	8	125.1	3	10
FCV-08D-30-4-314	8	125.1	3	14
FCV-08D-30-4-412	8	125.1	4	12
FCV-08D-30-4-414	8	125.1	4	14
FCV-10D-30-4-314	10	156.4	3	14
FCV-10D-30-4-410	10	156.4	4	10
FCV-10D-30-4-412	10	156.4	4	12
FCV-10D-30-4-414	10	156.4	4	14
FCV-12D-30-4-410	12	187.7	4	10
FCV-12D-30-4-412	12	187.7	4	12
FCV-12D-30-4-414	12	187.7	4	14

UNIT WEIGHTS AND VOLUMES

FLUID COOLER SINGLE WIDTH					
Model #	Cu. Ft.	Gallons	Water Wgt. Lbs.	Unit Wgt. Net	Shipping
FCV-01S-18-4-108	0.06	0.44	3.7	111	156
FCV-01S-18-4-208	0.12	0.88	7.3	126	170
FCV-01S-22-4-210	0.17	1.25	10.4	149	193
FCV-01S-22-4-310	0.25	1.88	15.7	167	211
FCV-02S-22-4-208	0.32	2.43	20.3	244	313
FCV-02S-22-4-310	0.49	3.64	30.4	274	343
FCV-02S-22-4-410	0.65	4.86	40.5	303	372
FCV-02S-26-4-208	0.78	5.80	48.4	558	670
FCV-02S-26-4-210	0.78	5.80	48.4	570	682
FCV-02S-26-4-308	1.16	8.70	72.5	653	763
FCV-02S-26-4-310	1.16	8.70	72.5	665	775
FCV-02S-30-4-214	0.78	5.80	48.4	583	693
FCV-02S-30-4-310	1.16	8.70	72.5	660	770
FCV-02S-30-4-314	1.16	8.70	72.5	670	780
FCV-02S-30-4-414	1.55	11.60	96.7	737	847
FCV-03S-30-4-210	1.73	12.93	107.9	953	1073
FCV-03S-30-4-314	1.73	12.93	107.9	970	1090
FCV-03S-30-4-412	2.30	17.24	143.8	1050	1170
FCV-04S-30-4-310	2.29	17.15	143.1	1191	1296
FCV-04S-30-4-314	2.29	17.15	143.1	1216	1321
FCV-04S-30-41412	3.06	22.87	190.8	1349	1454
FCV-04S-30-4-414	3.06	22.87	190.8	1374	1479
FCV-05S-30-4-314	2.86	21.40	178.5	1552	1682
FCV-05S-30-4-410	3.81	28.53	238.0	1687	1822
FCV-05S-30-4-412	3.81	28.53	238.0	1707	1842
FCV-05S-30-4-414	3.81	28.53	238.0	1727	1862
FCV-06S-30-4-410	4.57	34.19	285.2	1955	2115
FCV-06S-30-4-412	4.57	34.19	285.2	1985	2145
FCV-06S-30-4-414	4.57	34.19	285.2	2015	2175

FLUID COOLER DOUBLE WIDTH					
Model #	Cu. Ft.	Gallons	Water Wgt. Lbs.	Unit Wgt. Net	Shipping
FCV-04D-30-4-214	1.54	11.55	96.3	1080	1190
FCV-04D-30-4-310	2.32	17.32	144.5	1201	1371
FCV-04D-30-4-314	2.32	17.32	144.5	1230	1400
FCV-04D-30-4-412	3.09	23.09	192.6	1354	1534
FCV-04D-30-4-414	3.09	23.09	192.6	1380	1560
FCV-06D-30-4-214	2.30	17.20	143.5	1560	1720
FCV-06D-30-4-310	3.45	25.81	215.3	1771	1961
FCV-06D-30-4-312	3.45	25.81	215.3	1801	1991
FCV-06D-30-4-314	3.45	25.81	215.3	1831	2021
FCV-06D-30-4-412	4.60	34.41	287.1	1951	2141
FCV-06D-30-4-414	4.60	34.41	287.1	1990	2180
FCV-08D-30-4-310	4.60	34.30	286.2	2322	2532
FCV-08D-30-4-314	4.60	34.30	286.2	2373	2538
FCV-08D-30-4-412	6.11	45.74	381.5	2638	2848
FCV-08D-30-4-414	6.11	45.74	381.5	2701	2911
FCV-10D-30-4-314	5.72	42.79	357.0	2904	3164
FCV-10D-30-4-410	7.63	57.06	476.0	3140	3410
FCV-10D-30-4-412	7.63	57.06	476.0	3201	3471
FCV-10D-30-4-414	7.63	57.06	476.0	3260	3530
FCV-12D-30-4-410	9.14	68.38	570.5	3705	4025
FCV-12D-30-4-412	9.14	68.38	570.5	3770	4090
FCV-12D-30-4-414	9.14	68.38	570.5	3835	4155

FAN AND MOTOR DATA - SINGLE FAN-WIDTH UNITS

FLUID COOLER SINGLE WIDTH									
MODEL #	FAN DATA			MOTOR DATA					Noise Data (dba)
	Qty.	Dia. (in.)	Total CFM	Nom. H.P.	MIN. CIRCUIT AMPACITY				
					208-230 1 ph.	208-230 3 ph.	460 3 ph.	575 3 ph.	
FCV-01S-18-4-108	1	18	3100	1/2	15	15	15	15	70
FCV-01S-18-4-208	1	18	2550	1/2	15	15	15	15	70
FCV-01S-22-4-210	1	22	4350	1/2	15	15	15	15	71
FCV-01S-22-4-310	1	22	3900	1/2	15	15	15	15	71
FCV-02S-22-4-208	2	22	8900	1/2	15	15	15	15	72
FCV-02S-22-4-310	2	22	7800	1/2	15	15	15	15	72
FCV-02S-22-4-410	2	22	7100	1/2	15	15	15	15	73
FCV-02S-26-4-208	2	26	15200	1 1/2	N/A	15	15	15	73
FCV-02S-26-4-210	2	26	15000	1 1/2	N/A	15	15	15	76
FCV-02S-26-4-308	2	26	14850	1 1/2	N/A	15	15	15	76
FCV-02S-26-4-310	2	26	14600	1 1/2	N/A	15	15	15	76
FCV-02S-30-4-214	2	30	22400	1 1/2	N/A	15	15	15	76
FCV-02S-30-4-310	2	30	22000	1 1/2	N/A	15	15	15	76
FCV-02S-30-4-314	2	30	21200	1 1/2	N/A	15	15	15	76
FCV-02S-30-4-414	2	30	20000	1 1/2	N/A	15	15	15	76
FCV-03S-30-4-210	3	30	33000	1 1/2	N/A	21.1	15	15	78
FCV-03S-30-4-314	3	30	31800	1 1/2	N/A	21.1	15	15	78
FCV-03S-30-4-412	3	30	30900	1 1/2	N/A	21.1	15	15	78
FCV-04S-30-4-310	4	30	44000	1 1/2	N/A	27.6	15	15	80
FCV-04S-30-4-314	4	30	42400	1 1/2	N/A	27.6	15	15	80
FCV-04S-30-4-412	4	30	41200	1 1/2	N/A	27.6	15	15	80
FCV-04S-30-4-414	4	30	40000	1 1/2	N/A	27.6	15	15	80
FCV-05S-30-4-314	5	30	53000	1 1/2	N/A	34.1	17.3	15	81
FCV-05S-30-4-410	5	30	52630	1 1/2	N/A	34.1	17.3	15	81
FCV-05S-30-4-412	5	30	51500	1 1/2	N/A	34.1	17.3	15	81
FCV-05S-30-4-414	5	30	50000	1 1/2	N/A	34.1	17.3	15	81
FCV-06S-30-4-410	6	30	63150	1 1/2	N/A	40.6	20.6	15	82
FCV-06S-30-4-412	6	30	61800	1 1/2	N/A	40.6	20.6	15	82
FCV-06S-30-4-414	6	30	60000	1 1/2	N/A	40.6	20.6	15	82

FAN AND MOTOR DATA - DOUBLE FAN-WIDTH UNITS

FLUID COOLERS DOUBLE WIDTH									
MODEL #	FAN DATA			MOTOR DATA					
	Qty.	Dia. (in.)	Total CFM	Nom. H.P.	MIN. CIRCUIT AMPACITY				Noise Data (dba)
					208-230 1 ph.	208-230 3 ph.	460 3 ph.	575 3 ph.	
FCV-04D-30-4-214	4	30	44800	1 1/2	N/A	27.6	15	15	80
FCV-04D-30-4-310	4	30	44000	1 1/2	N/A	27.6	15	15	80
FCV-04D-30-4-314	4	30	42400	1 1/2	N/A	27.6	15	15	80
FCV-04D-30-4-412	4	30	41200	1 1/2	N/A	27.6	15	15	80
FCV-04D-30-4-414	4	30	40000	1 1/2	N/A	27.6	15	15	80
FCV-06D-30-4-214	6	30	67200	1 1/2	N/A	40.6	20.6	15	82
FCV-06D-30-4-310	6	30	66000	1 1/2	N/A	40.6	20.6	15	82
FCV-06D-30-4-312	6	30	64800	1 1/2	N/A	40.6	20.6	15	82
FCV-06D-30-4-314	6	30	63600	1 1/2	N/A	40.6	20.6	15	82
FCV-06D-30-4-412	6	30	61800	1 1/2	N/A	40.6	20.6	15	82
FCV-06D-30-4-414	6	30	60000	1 1/2	N/A	40.6	20.6	15	82
FCV-08D-30-4-310	8	30	88000	1 1/2	N/A	53.6	27.2	19.8	83
FCV-08D-30-4-314	8	30	84800	1 1/2	N/A	53.6	27.2	19.8	83
FCV-08D-30-4-412	8	30	82400	1 1/2	N/A	53.6	27.2	19.8	83
FCV-08D-30-4-414	8	30	80000	1 1/2	N/A	53.6	27.2	19.8	83
FCV-10D-30-4-314	10	30	106000	1 1/2	N/A	66.6	33.8	24.6	84
FCV-10D-30-4-410	10	30	105250	1 1/2	N/A	66.6	33.8	24.6	84
FCV-10D-30-4-412	10	30	103000	1 1/2	N/A	66.6	33.8	24.6	84
FCV-10D-30-4-414	10	30	100000	1 1/2	N/A	66.6	33.8	24.6	84
FCV-12D-30-4-410	12	30	126300	1 1/2	N/A	79.6	40.4	29.4	84
FCV-12D-30-4-412	12	30	123600	1 1/2	N/A	79.6	40.4	29.4	84
FCV-12D-30-4-414	12	30	120000	1 1/2	N/A	79.6	40.4	29.4	84

SINGLE FAN UNITS FCV-01S-18-4-108 & FCV-01S-18-4-208

END VIEW

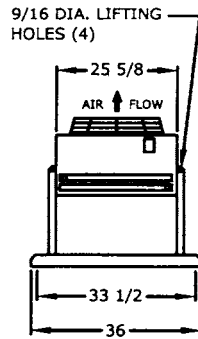

SIDE VIEW

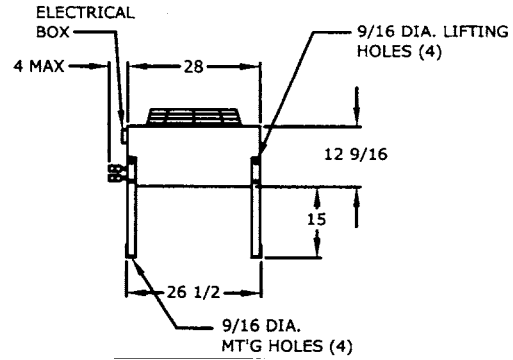

SINGLE FAN UNITS FCV-01S-22-4-210 & FCV-01S-22-4-310

END VIEW

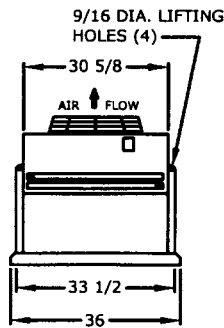

SIDE VIEW

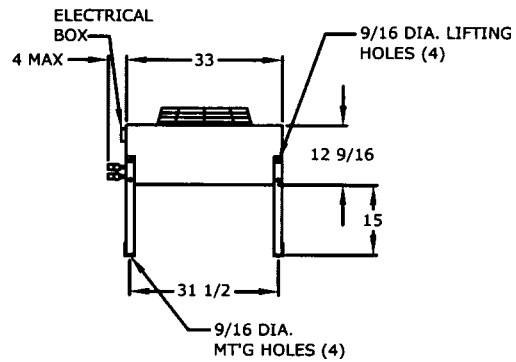

SINGLE FAN UNITS FCV-02S-22-4-208 THRU FCV-02S-22-4-410

END VIEW

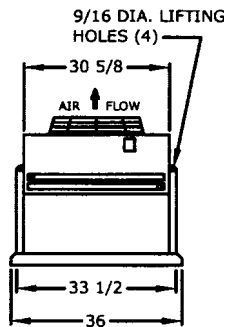

SIDE VIEW

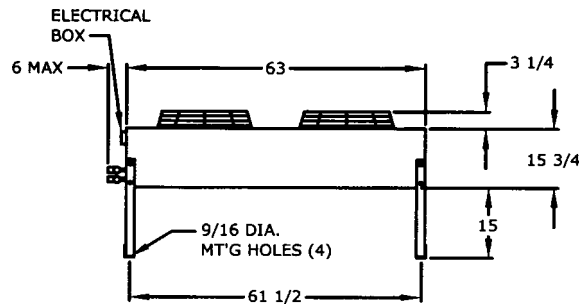

SINGLE FAN UNITS FCV-02S-26-4-208 THRU FCV-02S-30-4-414

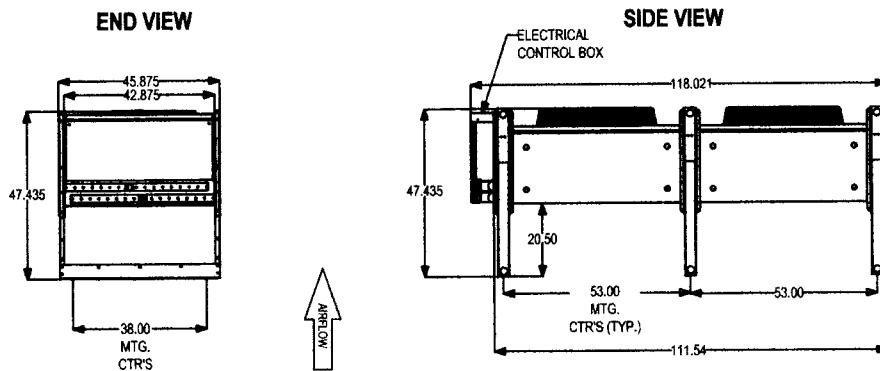

SINGLE UNITS FCV-03S-30-4-310 THRU FCV-03S-30-4-412

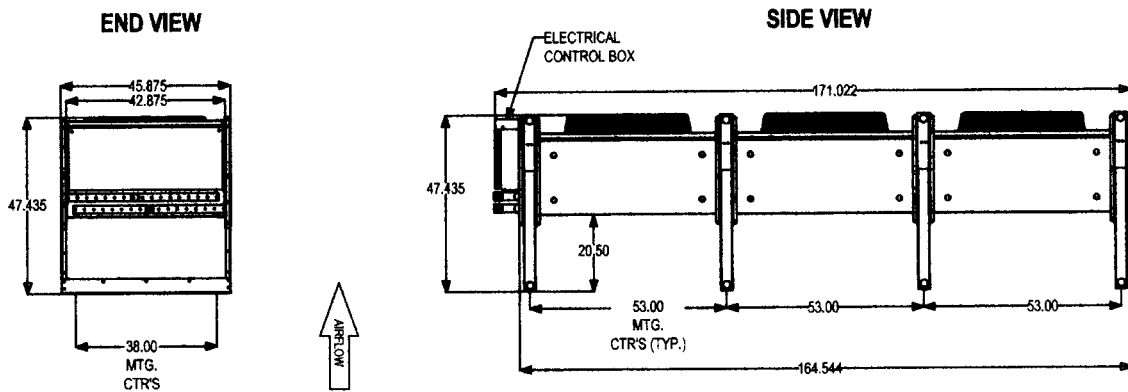

SINGLE UNITS FCV-04S-30-4-310 THRU FCV-04S-30-4-414

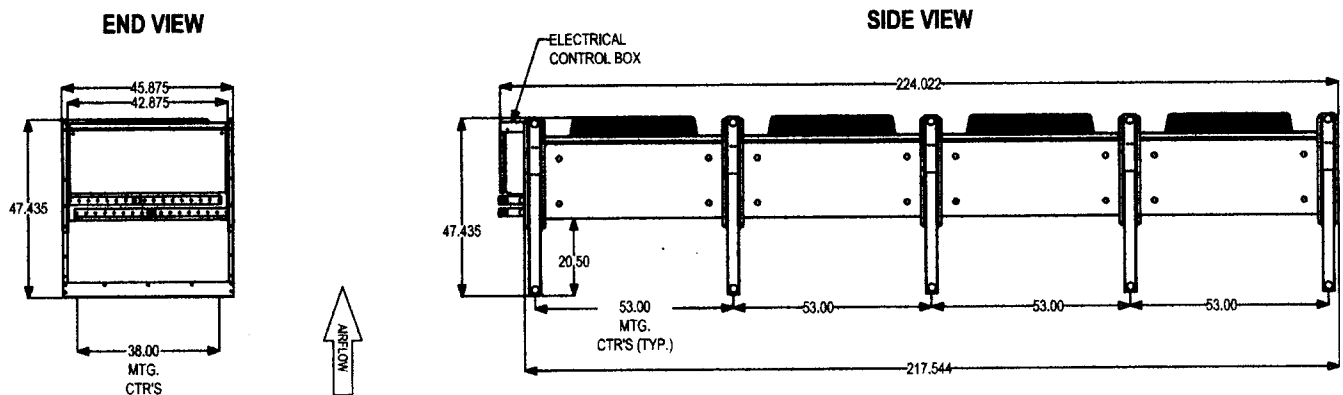

SINGLE UNITS FCV-05S-30-4-314 THRU FCV-05S-30-4-414

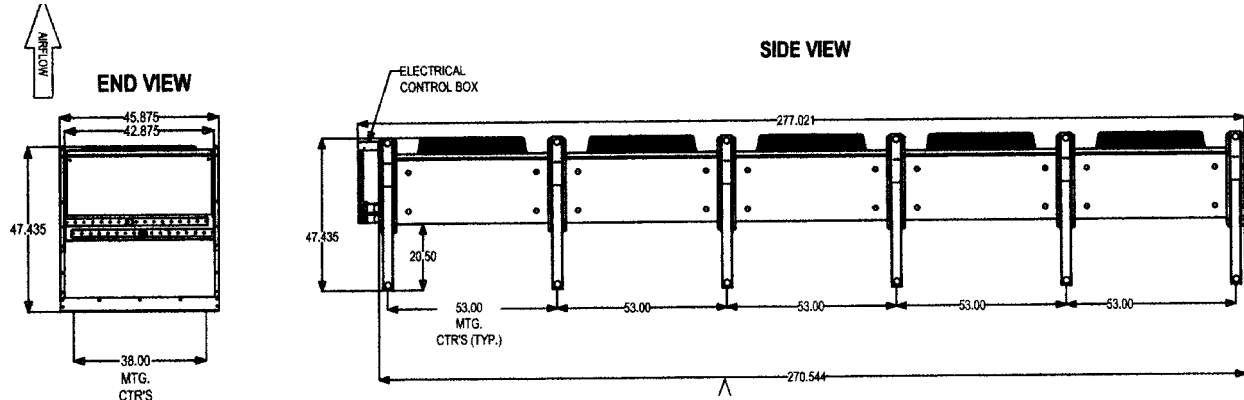

SINGLE UNITS FCV-06S-30-4-410 THRU FCV-06S-30-4-414

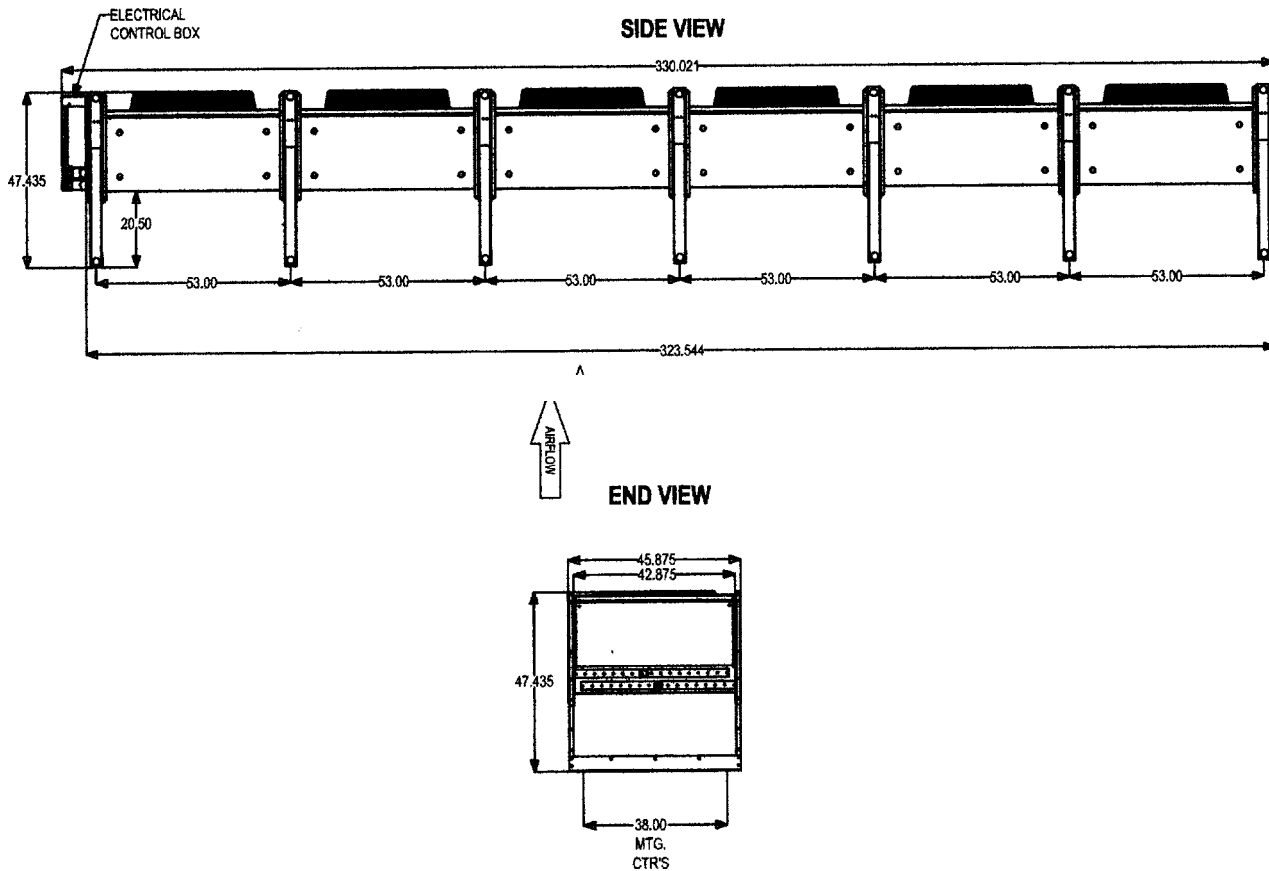

DOUBLE FAN UNITS FCV-04D-30-4-214 THRU FCV-04D-30-4-414

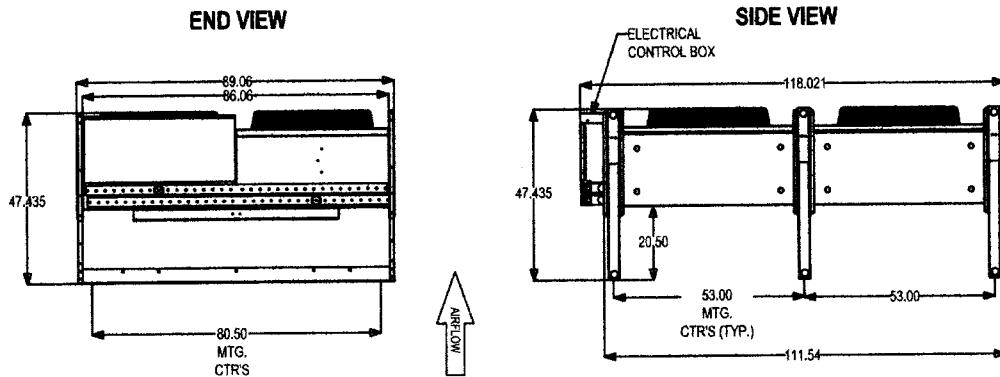

DOUBLE UNITS FCV-06D-30-4-214 THRU FCV-06D-30-4-414

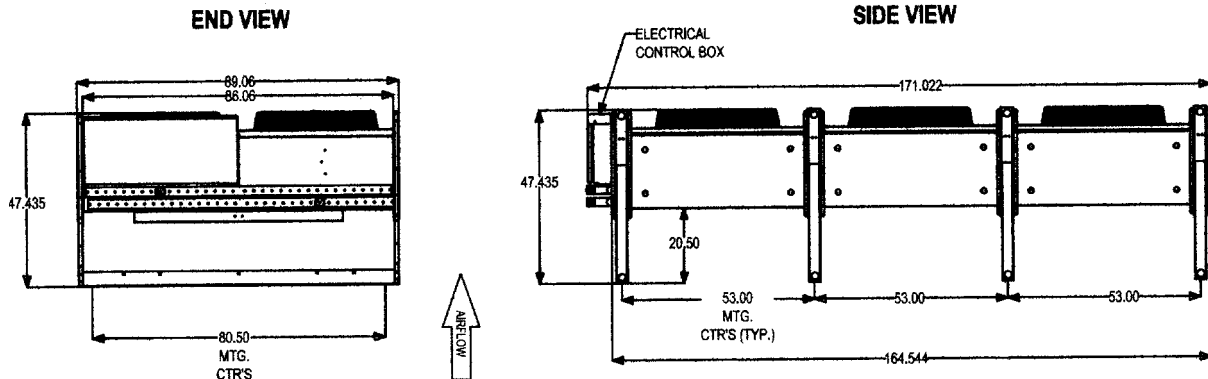

DOUBLE UNITS FCV-08D-30-4-310 THRU FCV-08D-30-4-414

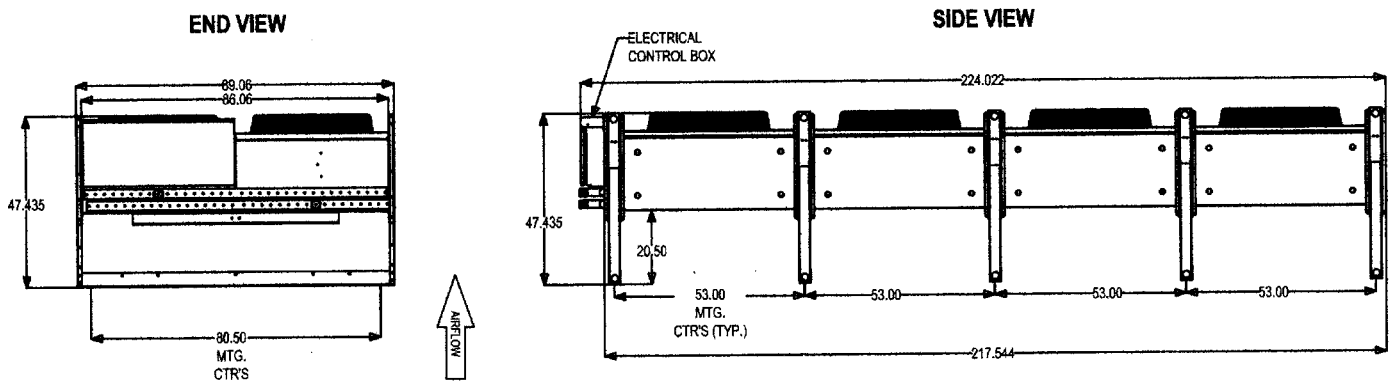

DOUBLE UNITS FCV-10D-30-4-314 THRU FCV-10D-30-4-414

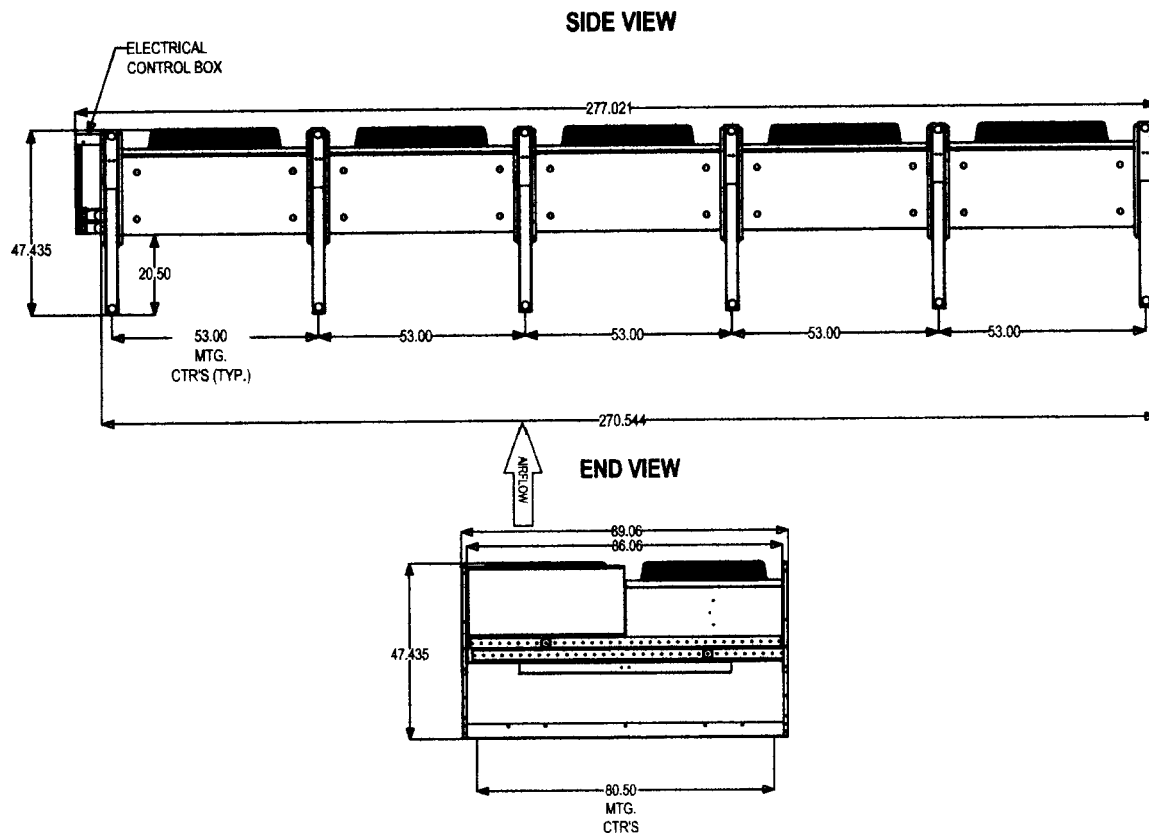

DOUBLE UNITS FCV-12D-30-4-410 THRU FCV-12D-30-4-414

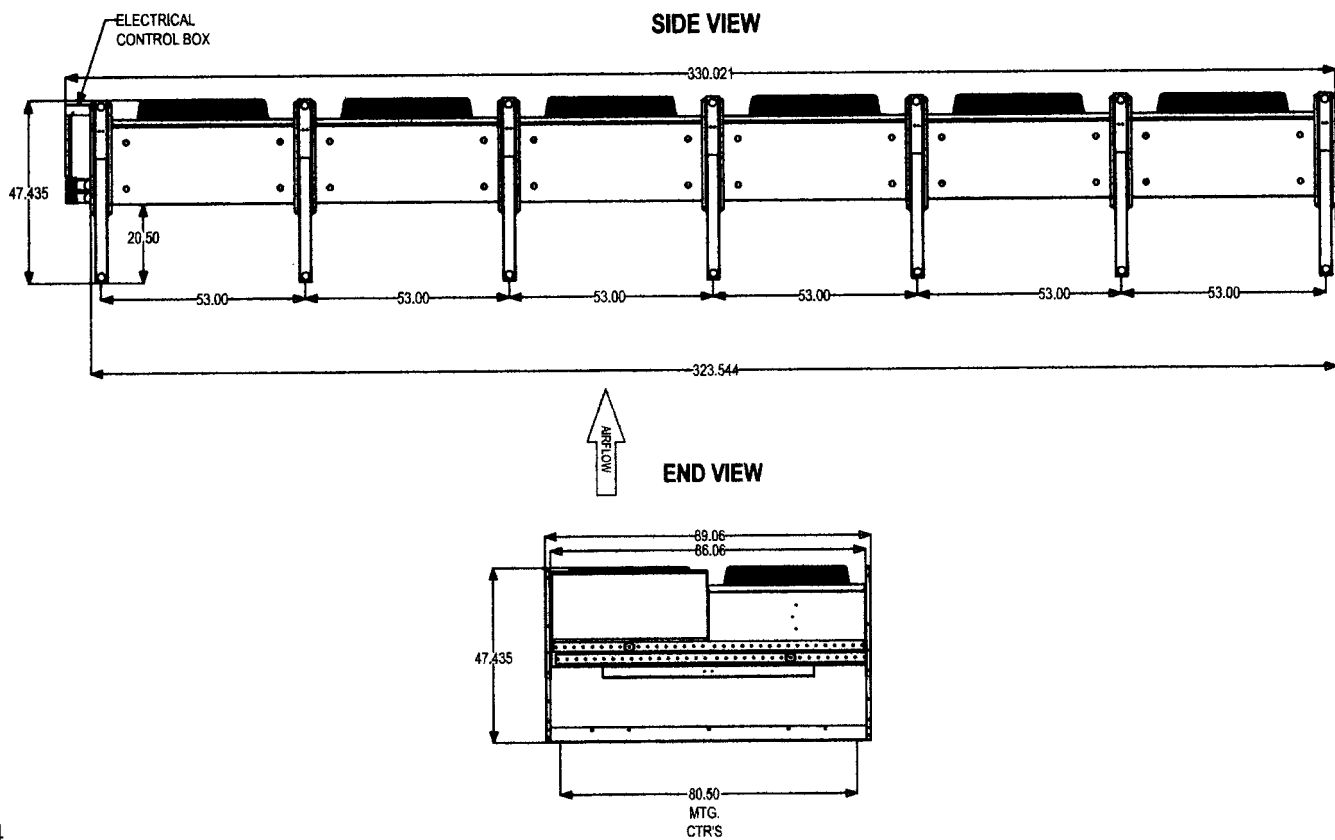

STANDARD 18" LEG AND OPTIONAL 30" LEG DIMENSIONS

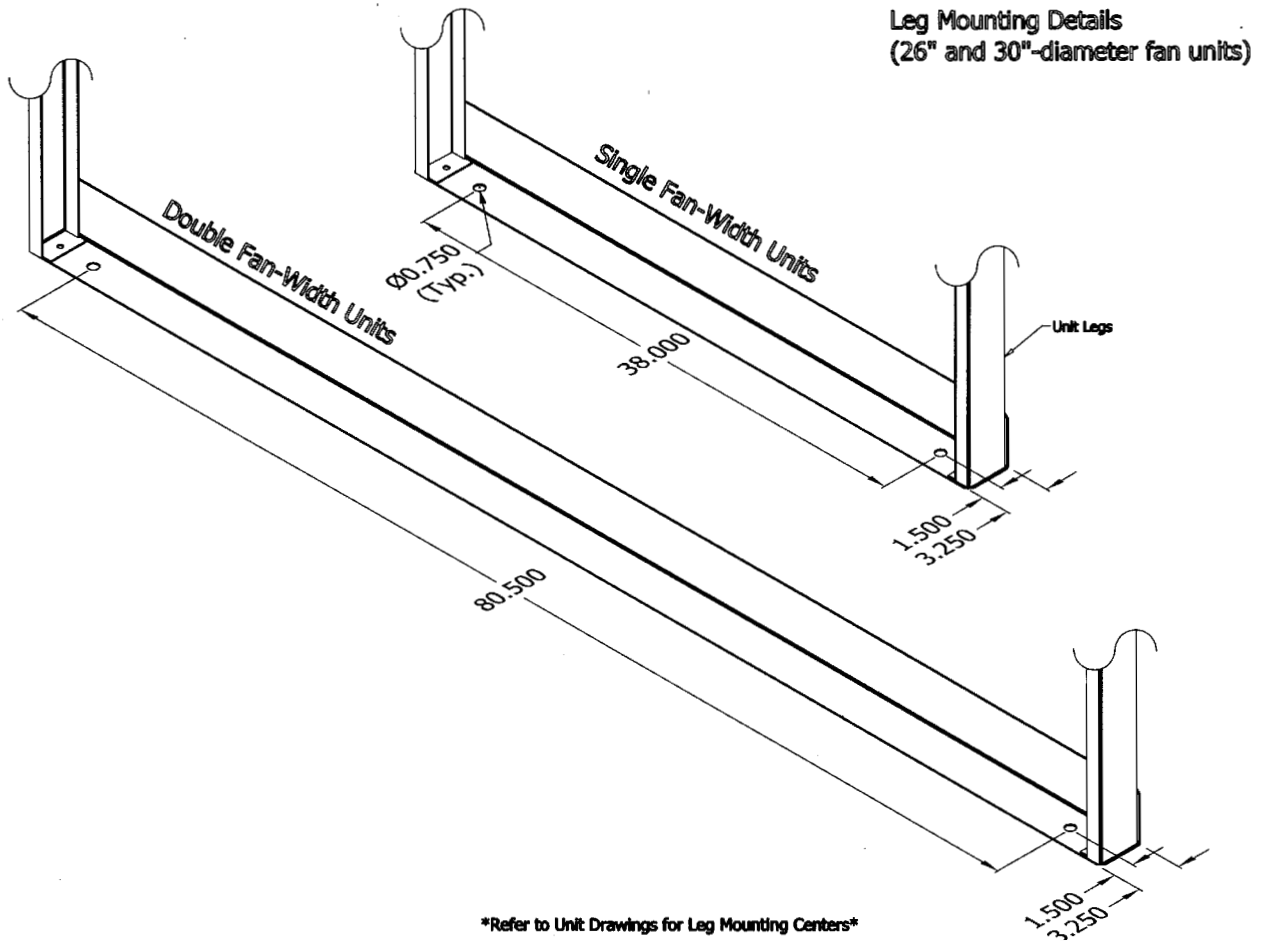

CONNECTION SIZES* +

GPM RANGE	INLET & OUTLET	
	QTY.	SIZE
10-20	1	1 1/4
20-40	1	1 1/2
40-70	1	2
70-100	1	2 1/2
100-150	1	3
150-200	2	2 1/2
200-300	2	3
300-450	3	3
450-550	4	3

+ All connections are MPT

MOTOR AMPS

HP	MOTOR AMPS	
	VOLTS/PHS/CYL	AMPS
1/2 HP	208-230/1/60	2.5A
	208-230/3/60	2.0A
	460/3/60	1.0A
	575/1/60	1.0A
1 1/2 HP	208-230/1/60	N/A
	208-230/3/60	6.5A
	460/3/60	3.3A
	575/1/60	2.4A

*Contact factory for exact location of connections on header. Some units may have split headers.